

Surge Protective Devices

TranTrack LP Series: 100

Installation,
Operation and
Maintenance
Manual

TABLE OF CONTENTS

Before Installation	3
<i>System Configuration Verification</i>	3
<i>Environmental Condition Verification</i>	4
<i>Wiring Connection Diagrams</i>	4
<i>Upstream Over-Current Protection Device</i>	4
<i>Conductor Routing</i>	4
<i>Mounting</i>	5 - 8
<i>Enclosure and Trim Plate Dimensional Drawings</i>	5
<i>Drywall has not been installed</i>	6
<i>Drywall is installed</i>	7
<i>Sample install pictures</i>	8
<i>Electrical Connections</i>	9
<i>Verification and Power Up</i>	10
Troubleshooting	10
Warranty Statement	10

BEFORE INSTALLATION



WARNING: HAZARDOUS VOLTAGES PRESENT Improper installation or misapplication may result in serious personnel injury and/or damage to electrical system. Read the complete installation instructions before proceeding with installation. Remove all power to the electrical panel before installing or servicing the surge protective device (SPD).

IMPORTANT SAFETY INSTRUCTIONS All work must be performed by licensed and qualified personnel. The electrical system must be properly grounded in accordance with the U.S. National Electrical Code, state and local codes or other applicable codes for this SPD to function properly. Do not connect TransTrack LP to the line side of the main service breaker or disconnecting means. This device is suitable for installation where the available short circuit current is 200,000 rms symmetrical amperes at 600VAC or less.



WARNING: Check to ensure that a proper bond is installed between neutral and ground at the transformer upstream from the split-phase TransTrack LP device (See NEC Article 250). If the transformer is not accessible, check the main service disconnect/panel for the N-G bond. Lack of a proper bond will damage TransTrack LP and void the warranty.

To ensure optimum home surge protection, all home services – power, telephone and CATV/satellite – should be properly installed and connected to the same ground point. Failure to follow these instructions may lead to the damage of connected equipment from transients, internal and external surges and lightning.

NOTE: To provide adequate protection to all electrical and electronic equipment in the home it is recommended that all electrical panels, telephone, cable TV and data lines be protected with Total Protection Solutions surge protection devices.

1. System Configuration Verification

Confirm that the voltage and service configuration shown on the TransTrack LP product label is consistent with the voltage and service configuration of the location. The model number is located on a label on the outside of unit.

MODEL NUMBER	NOMINAL VOLTAGE	L-N VOLTAGE RANGE	L-L VOLTAGE RANGE	CONFIGURATION
TK-TTLP-1S240-FL	120/240	108-132	216-264	Split-Phase, 3-wire+ground
TK-TTLP-3Y208-FL	120/208	108-132	187-228	3-Phase, 4-wire+ground
TK-TTLP-3Y480-FL	277/480	249-305	432-528	3-Phase, 4-wire+ground

100kA surge rating per phase

2. Environmental Condition Verification

Confirm that the environmental conditions are consistent with the following ranges:

- Ambient Temperatures: Between -40° and +158°F.
- Relative Humidity: Between 5% and 95% non-condensing.
- Altitude: Less than 13,000 feet.

3. Wiring Connection Diagrams

Figure 1 shows the electrical relationship between TransTrack LP and the service configuration: Split phase, 3 wire.

Fig. 1: Split Phase, 3-Wire + Ground

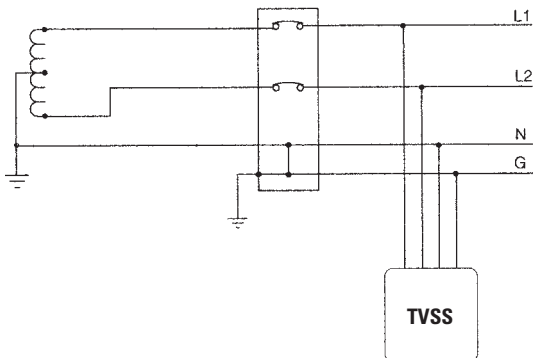
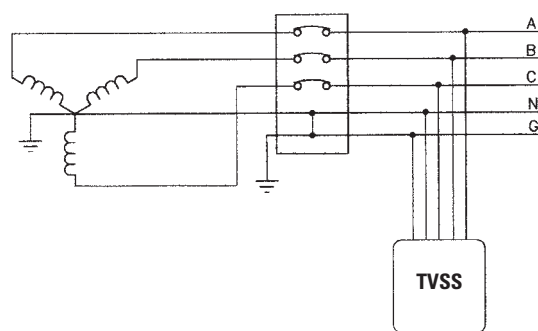

Fig. 2: 3-Phase, 4-Wire + Ground



Connections to the SPD are clearly identified and are made via pigtail leads supplied with the unit. The phase connections are marked “A/L1” and “C/L2”, A, B, and C for 3-phase systems. The Neutral is a white wire and the Ground is a green wire.

4. Upstream Over-Current Protection Device

TransTrack LP must be connected in parallel to the electrical system.

TransTrack LP units have built-in over-current fusing rated at 200,000 rms symmetrical ampere at 600VAC or less and can be connected directly to the electrical distribution system bus without an upstream over-current protection device. TransTrack LP units are listed as Type1 SPDs per UL 1449 3rd Edition and can be installed on the line or load side of the main service disconnect. However, the use of an external over current protection device is recommended.

If the TransTrack LP is connected to a dedicated overcurrent protection device, a 30A breaker is recommended (30A minimum, 400A maximum). The advantage of using a dedicated over-current device for the TransTrack LP (even if the upstream breaker is 400A or less) is that it allows the TransTrack LP to be de-energized during service without disturbing the electrical service to the rest of the facility.



TransTrack LP's performance will be limited severely if the conductors are (a) too long, (b) have too many bends or (c) have sharp bends.

5. Conductor Routing

The factors listed above should be addressed during the design of an installation to reserve a suitable place for TransTrack LP next to its point of connection to the electrical system.

The selected mounting location should allow for the shortest possible conductor runs and a direct route with a minimum of bends. If bends are required, they should be *sweeping* bends. Do not make sharp 90° bends for appearance purposes because they will severely decrease the effectiveness of TransTrack LP.

Binding or twisting conductors together using tie-wraps or electrical tape increases the protection performance of the device.

6. Mounting

TransTrack LP can be mounted in a variety of methods. The basic method is to wall mount using the mounting feet attached to the base of the enclosure. TransTrack LP can also be flush-mounted to the exterior wall surface, using the trim plate provided to cover the hole created in the dry wall. Mount TransTrack LP using construction methods and hardware appropriate for your site. The TransTrack LP enclosure is designed with a 1/2-inch myers hub which will accept rigid or IMC conduit. See Figure 2 and 3 for enclosure and trim plate dimensions.

Fig. 2
TTLP Dimensions

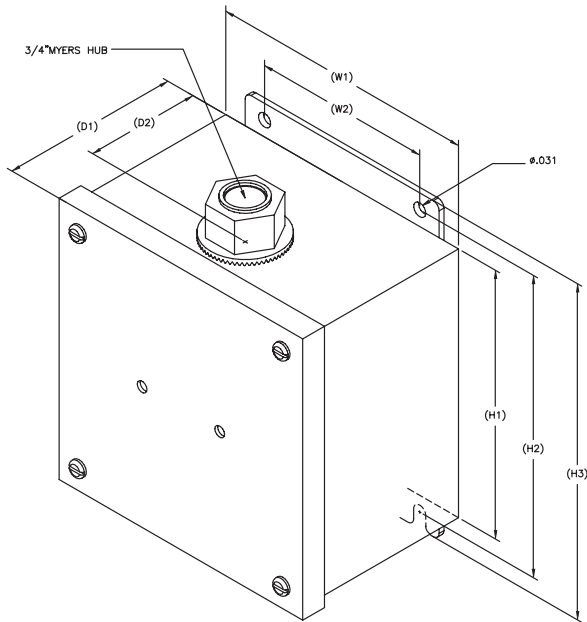
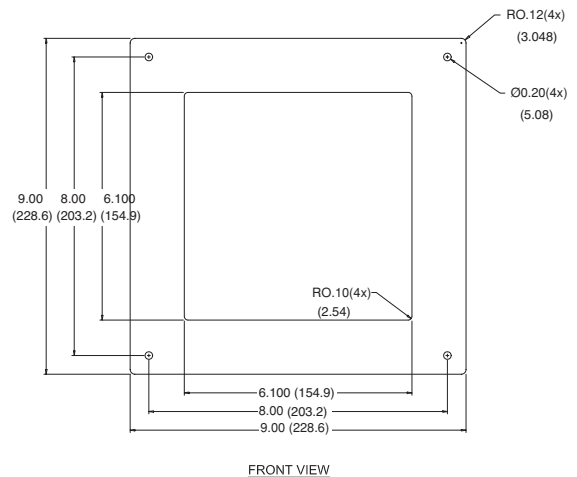

Fig. 3:
Trim Plate Dimensions



NOTES:
 1. DRAWING TO BE INTERPRETED PER ANSI STANDARD Y14.5.
 2. ALL DIMENSIONS ARE IN INCHES.
 3. DEBURR ALL SHARP EDGES AND CORNERS, SAND SMOOTH.
 4. RADII TO BE .07 MAX.

All measurements in inches (mm)

TTLP Dimensions

DIM	IN	(mm)
H1	6.00	(152.4)
H2	6.75	(171.5)
H3	7.50	(190.5)
W1	6.00	(152.4)
W2	4.00	(101.6)
D1	4.16	(105.7)
D2	2.50	(63.5)

All measurements in inches (mm)

Mounting Instructions (if drywall has not been installed)

1. For this installation there needs to be a 2-pole 30 AMP(minimum) breaker available in the AC panel for wiring the TK-TTLP-1S240-FL.
2. If there is NO POWER to the AC panel skip to step 4.
3. If power has already been provided to the AC panel, you will need to trip the MAIN BREAKER to the panel and remove the cover plate to the panel.
4. Route all 4 wires of the TTLP through the 1/2" x 2" offset nipple (provided in hardware kit of AC unit) and tighten offset nipple to the Meyer's hub of the TTLP unit.
5. Knock out or drill a 1/2" hole in the side of the AC panel where the TTLP unit is to be installed. It is recommended that the TTLP installation placement be as close as possible to the breaker, neutral bus, and ground bus for optimum performance.
6. Insert the end of the 1/2" x 2" offset nipple through that hole and secure offset nipple with the lock washer (provided in the hardware kit of the AC unit).
7. Install 3/4" bushing (provide in the hardware kit of the AC unit) onto the end of the offset nipple inside the AC panel. This will prevent the wires of the TTLP unit from rubbing against the metal of the offset nipple.
8. Connect the Green wire of the TTLP unit to the Ground terminal of the AC panel. Avoid 90 Degree bends in the wire, and if bends are required make them sweeping bends. Remove any excess ground (green) wire not required before connecting to the Ground terminal.
9. Connect the White wire of the TTLP unit to the Neutral terminal of the AC panel. Avoid 90 Degree bends in the wire and if bends are required make them sweeping bends. Remove any excess Neutral (White) wire not required before connecting to the Neutral terminal.
10. Connect the (2) black wires to the 2-pole, 30 AMP breaker. Avoid 90 Degree bends in the wires and if bends are required make them sweeping bends. Remove any excess wire not required before connecting to the breaker.
11. If power to the AC panel has not been run yet skip to step 14.
12. If the AC panel can be turned "ON", turn power on to the panel by turning the Main Breaker "ON", then turn the 30 AMP breaker for the TTLP "ON" and verify both LED lights are illuminated. If LEDs are not present contact Manufacturer using contact information found at the end of this manual. If LED lights do turn on, unit is functioning properly.
13. Included in the TTLP packaging is a trim plate and a plastic protector. Set trim plate aside for use after drywall and painting have been completed. Remove plastic protector and install over the front of the TTLP unit. This will protect the unit and keep it clean during the drywall installation and painting.
14. Once drywall and painting have been completed, remove plastic protector and remove cover to the TTLP unit. Manipulate the cover of the TTLP unit through the trim plate opening and install trim plate around the base of the enclosure until flush to the wall. Re-install cover to the TTLP unit.

Mounting Instructions (if drywall is installed)

1. For this installation there needs to be a 2-pole 30 AMP(minimum) breaker available in the AC panel for wiring the TK-TTLP-1S240-FL.
2. If there is NO POWER to the AC panel skip to step 4.
3. If power has already been provided to the AC panel, you will need to trip the MAIN BREAKER to the panel and remove the cover plate to the panel.
4. Route all 4 wires of the TTLP through the 1/2" x 2" offset nipple (provided in hardware kit of AC unit) and tighten offset nipple to the Meyer's hub of the TTLP unit.
5. The hole that needs to be created in the dry wall for the TTLP unit can be as large as 8" x 8". The actual hole required is 7.5" x 6". (DO NOT EXCEED over 8 1/2" in either direction or the trim plate may not cover the hole created). Care should be taken to insure the open air space behind the cut out is sufficient to fit TTLP unit.
6. Knock out or drill a 1" hole in the side of the AC panel where the TTLP unit is to be installed.
7. Insert the end of the 1/2" x 2" offset nipple through that hole and secure offset nipple with the lock washer (provided in the hardware kit of the AC unit).
8. Install 3/4" bushing (provide in the hardware kit of the AC unit) onto the end of the offset nipple inside the AC panel. This will prevent the wires of the TTLP unit from rubbing against the metal of the offset nipple.
9. Connect the Green wire of the TTLP unit to the Ground terminal of the AC panel. Avoid 90 Degree bends in the wire and if bends are required make them sweeping bends. Remove any excess ground (green) wire not required before connecting to the Ground terminal.
10. Connect the White wire of the TTLP unit to the Neutral terminal of the AC panel. Avoid 90 Degree bends in the wire and if bends are required make them sweeping bends. Remove any excess Neutral (White) wire not required before connecting to the Neutral terminal.
11. Connect the (2) black wires to the 2-pole, 30 AMP breaker. Avoid 90 degree bends in the wires and if bends are required make them sweeping bends. Remove any excess wire not required before connecting to the breaker.
12. If power to the AC panel has not been run yet skip to step 14.
13. If the AC panel can be turned "ON", turn power on to the panel by turning the Main Breaker "ON", then turn the 30 AMP breaker for the TTLP "ON" and verify both LED lights are illuminated. If LEDs are not present contact Manufacturer using contact information found at the end of this manual. If LED lights do turn on, unit is functioning properly.
14. Remove cover to the TTLP unit. Manipulate the cover of the TTLP unit through the trim plate opening and install trim plate around the base of the enclosure until is flush to the sheetrock. Re-install cover to the TTLP unit.

Note: If walls have not been textured and/or painted, set trim plate aside for use after drywall and painting have been completed. Remove plastic protector and install over the front of the TTLP unit. This will protect the unit and keep it clean during drywall texturing and painting.

Sample Installation Pictures



Fig. 4
Sample picture of completely installed unit



Fig. 5
Sample picture of ground connection
to AC panel



Fig. 6
Sample picture of unit installed and
Operating properly

8. Electrical Connections



CAUTION: Prior to installation ensure the system configuration and voltage is equivalent to the TransTrack LP unit being installed.

Following all applicable National Electrical Code standards as well as state and local codes, connect phase, neutral and ground to TransTrack LP. Ensure that the conductor lengths are kept as short and straight as possible.

9. Verification and Power Up

Apply power to TransTrack LP by closing the over-current protection device or switch feeding the suppressor.

Fig. 7
TransTrack LP Diagnostics

Verify that all “Phase Protection Status” indicating lights are illuminated.



TROUBLESHOOTING

Your TransTrack LP system does not require scheduled maintenance. The unit's heavy-duty construction is designed to provide years of uninterrupted service. The unit contains no serviceable parts.

INDICATION	PROCEDURE
One or more phase protection status indicating lights are off.	Verify that the input power feeding TransTrack LP is energized using a voltage tester. If power is present, contact factory for assistance: www.SurgePack.com

INFORMATION	EXAMPLE
Model Number	TK-TTLP-1S240-FL
Serial Number	16230-0104-002
Date of Purchase	January 2, 2006
Sales Order Number	16230
Description of Failure	Phase Light Extinguished
Desired Action from Joslyn	Replace

WARRANTY STATEMENT

During the applicable warranty period, any Total Protection Solutions® surge protector device which fails due to defect in materials, workmanship, or any transient surge event to include lightning, shall be repaired or replaced at the expense of Total Protection Solutions.

Prior to shipment of any suspect or known defective product a Return Material Authorization (RMA) number must be obtained. An official RMA number and shipping instructions can be obtained from the distributor where the product was originally purchased. Distributors can obtain the official RMA number by contacting the Total Protection Solutions Customer Service Department at 800-604-9980. Products arriving without an official RMA number will not be accepted and will be returned freight collect to the original point of shipment.

Products being returned with an official RMA number should be shipped by prepaid freight to the nominated point of return as shown on the RMA documentation.

The Company shall have no liability under this warranty for problems or defects directly or indirectly caused by misuse of the Product, alteration of the Product (including removal of any warning labels), accidents, improper installation, application, operation or improper repair of the Product.

THIS WARRANTY REPRESENTS THE ENTIRE WARRANTY OF THE COMPANY. ALL OTHER WARRANTIES EXPRESS OR IMPLIED, ORAL OR WRITTEN, INCLUDING, BUT NOT LIMITED TO, THE WARRANTIES OF MERCHANTABILITY AND FITNESS FOR A PARTICULAR PURPOSE ARE HEREBY DISCLAIMED. THE LIABILITY OF THE COMPANY, AT ITS SOLE OPTION, UNDER THIS WARRANTY IS EXPRESSLY LIMITED TO THE REPLACEMENT OR REPAIR OF THE DEFECTIVE PART THEREOF. IN NO EVENT SHALL THE COMPANY BE LIABLE OR RESPONSIBLE FOR SPECIAL, INCIDENTAL, OR CONSEQUENTIAL DAMAGES OF ANY KIND OR CHARACTER, NOR SHALL ITS LIABILITY EVER EXCEED THE PURCHASE PRICE PAID FOR SUCH DEFECTIVE PRODUCT.

This warranty is not transferable and may only be enforced by the original purchaser. Claims under this warranty must be submitted to Total Protection Solutions within thirty (30) days of discovery of any suspected product defect.

Warranty Period

TransTrack® LP 25 years



4366 L. B. McLeod Rd.
Orlando, FL 32811-5619 USA
TEL: 800-604-9980
www.TPSSurge.com